

**HELLO**

**EFM<sup>®</sup> AUSTIN STUDIO ANC HEADPHONES**

User Manual



**HELLO!**

**Thank you for choosing the EFM<sup>®</sup> Austin Studio ANC Headphones.  
You can now enjoy an immersive listening experience anywhere, anytime.  
The EFM<sup>®</sup> Austin Studio ANC Headphones can be used with iOS and Android, and all  
other Bluetooth compatible devices to stream your favourite tunes and for handsfree calling.**

**For best results, please read this manual first.**

**PACK CONTENTS:**

- 1 x EFM<sup>®</sup> Austin Studio ANC Headphones**
- 1 x 0.6m Micro USB Charging Cable**
- 1 x 1.2m 3.5mm AUX Cable**
- 1 x User Manual & Warranty**
- 1 x EFM<sup>®</sup> Carry Pouch**

**Specifications**

- Weight: 230g
- Impedance: 32Ω
- Charging: Micro-USB
- Noise Reduction: 35dB
- Frequency Range:
  - 20Hz ~20,000 Hz (Bluetooth)
  - 10Hz ~ 40,000 Hz (3.5mm AUX Cable)
- Audio Connector: Bluetooth / 3.5mm AUX Cable
- Monitor Function: Amplify the ambient sound
- Microphone: ANC Mic x 4, Talk Mic x 1

**Wearing The Headphones**

To find the best fit, try adjusting the headphones to a comfortable position on your ear.  
Distinguish between left and right ear cups. Have the left ear cup marked “L” on your left ear and the right one marked “R” on your right ear.

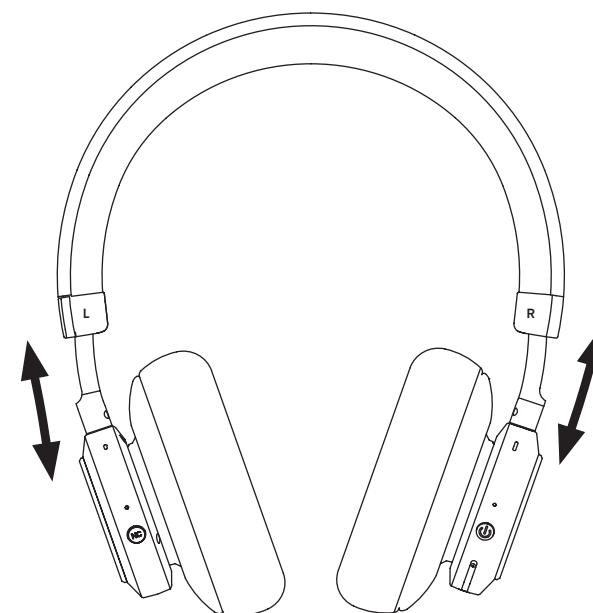

**Call Functions**

- ⏻ Press once to answer/end the call
- ⏻ Press and hold for 1 second to reject the call
- ⏻ Press twice quickly to redial
- 🔊+ Press once to increase volume
- 🔊- Press once to decrease volume

**Music Controls**



- ⏻ Press once to play/pause the music
- 🔊+ Press once to increase the volume
- 🔊- Press once to decrease the volume
- 🔊+ Press and hold for 1 second to switch to next track
- 🔊- Press and hold for 1 second to switch to previous track

**Other Controls**

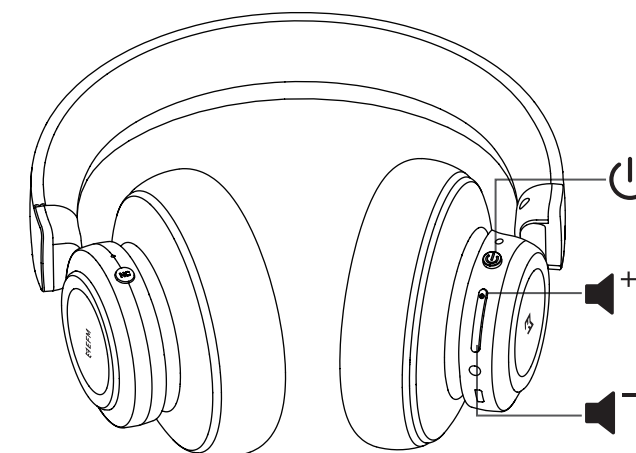
- ⏻ Press and hold for 1 second to turn on the headphones
- ⏻ Press and hold for 3 seconds to turn off the headphones
- ⏻ With the headphones off, press and hold for 3 seconds to pair the device
- ⏻ With the headphones on, press and hold for 1 second to activate voice control assistant (Controls may vary on different devices)



## Wireless Pairing

1. With the headphones off, press and hold  for 3 seconds until LED flashes red/green to pair with the device (If the pairing is unsuccessful, press and hold  for 3 second to switch headphones off then repeat process above).

2. To pair EFM<sup>®</sup> Austin Studio ANC Headphones with your device, turn Bluetooth On to search for device and select “EFM Austin Studio ANC” from the list.

### Tips:

Devices already paired will automatically reconnect with the EFM Austin Studio ANC using automatic pairing feature.

## Multi-Function Touch Controls

The Multi-Function Touch Control is located on the outside of the right ear cup for touch sensitive quick access.

## Music Controls

Double tap to play/ pause the music.

## Call Functions

Double tap to answer a call. Double tap again to end a call.

## Awareness Mode Control

Placing your hand on the right ear touch control will activate the awareness monitoring mode, decreasing the audio volume allowing you hear the ambient sound around you.

## Noise Reduction/Normal Mode/ Monitor Mode

Four modes are available: Noise reduction medium, noise reduction high, normal mode and monitor mode. When you power on the headphones, the normal mode is activated.







## Switching Between Modes

Press “NC” once to turn on the noise reduction medium function. Press again to switch to noise reduction high function. Press again to switch to normal mode. Press & hold “NC” switch to awareness monitor mode.

## Voice Prompt

When the noise reduction medium function is selected, a voice prompt will say “Noise reduction medium”. When the noise reduction high function is selected, a voice prompt will say “Noise reduction high”. When normal mode is selected, a voice prompt will say “Noise reduction off”. When the monitor function is turned on, a voice prompt will say “Monitor mode”.

## Button Function Controls

Function	Action	LED Indicator
Power On	Press  for 1 second	Green LED On for 1.5 seconds
Pairing	With the headphones Off, Press and hold  for 3 seconds	Green and red alternates
Power Off	Press and hold  for 3 seconds	Red LED On for 2 seconds
Switch to last song	Press “Volume down” for 1 second	
Switch to next song	Press “Volume up” for 1 second	
Play/Pause	Press  once / Double tap on the Multi-function touch control	
Activate Voice Control Assistant	With the headphones On, press and hold  for 1 second	
Answer/End the call	Press  once / Double tap on the Multi-function touch control	
Reject the call	Press and hold  for 1 second	
Volume up	Press the “Volume up” once	
Volume down	Press the “Volume down” once	
Noise Reduction Medium Noise Reduction High Normal Mode	Press “NC” and switch between noise reduction medium/ noise reduction high/ normal mode. Press and hold “NC” for 1 second until you hear the voice prompt to activate the monitor function; Press “NC” again will return to the last mode.	Green LED light Green LED light Green LED light off
Monitor Mode		Green LED light

## Using the 3.5mm AUX Cable

EFM<sup>®</sup> Austin Studio ANC Headphones can connect to other devices using the 3.5mm AUX Cable. When the headphones run out of battery, plug in the 3.5mm AUX cable and the headphones can be used to listen to music while all the buttons are disabled and the active noise cancelling function is off. When the headphones still have battery, plug the 3.5mm AUX Cable in and the noise cancelling function can still be activated while the Bluetooth function and all other features are disabled.

### Tips:

1. Unplug the headphones to turn off.
2. There’s no voice prompt during the switch between noise cancelling function and other modes, while cable is plugged in.
3. The 3.5mm AUX cable is specially designed for situations when you can not connect to bluetooth, or if you prefer a wired connection.

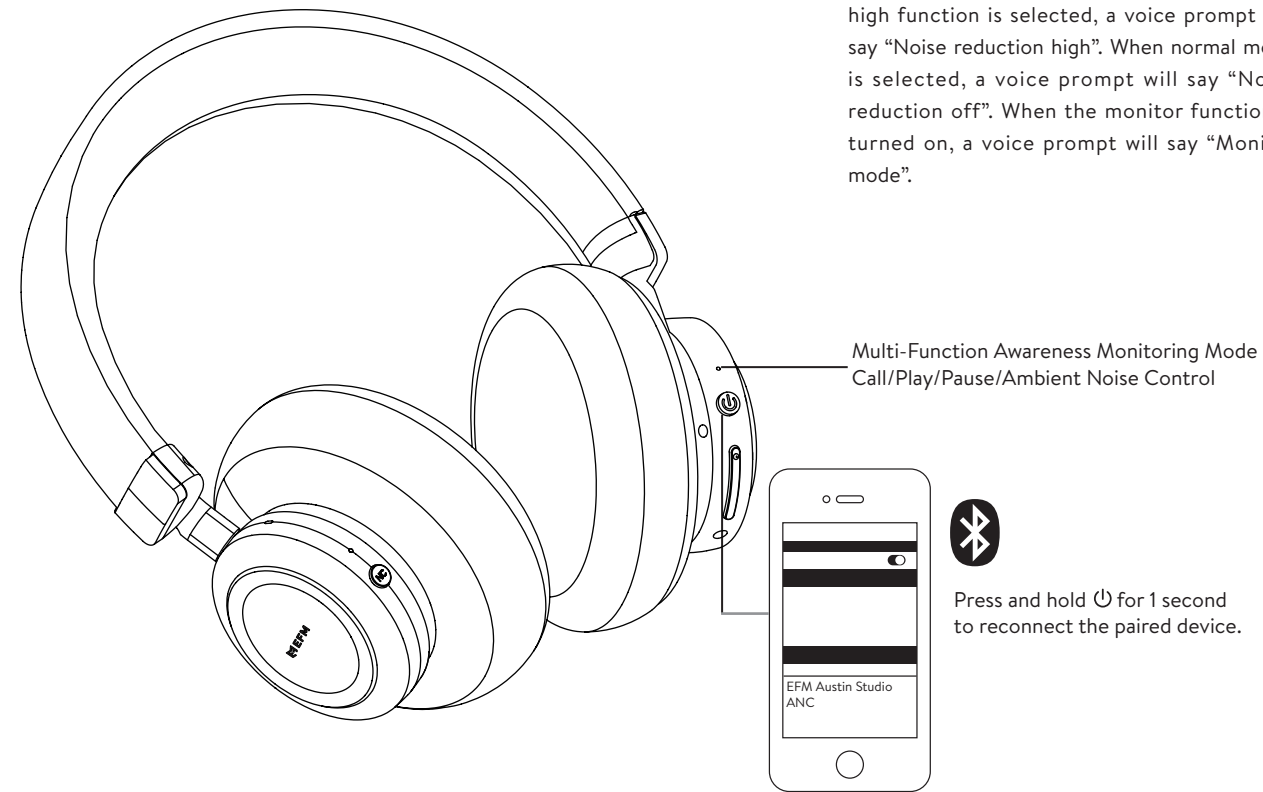

Press and hold  for 1 second to reconnect the paired device.

1. Multi-Function Touch Control
2. Dual Active Noise Cancelling Control
3. Dual Active Noise Cancelling Control Indicator
4. LED Light Indicator
5. Power & Bluetooth Control
6. Volume Up
7. Volume Down
8. 3.5mm AUX Cable Port
9. Micro-USB Charging Port

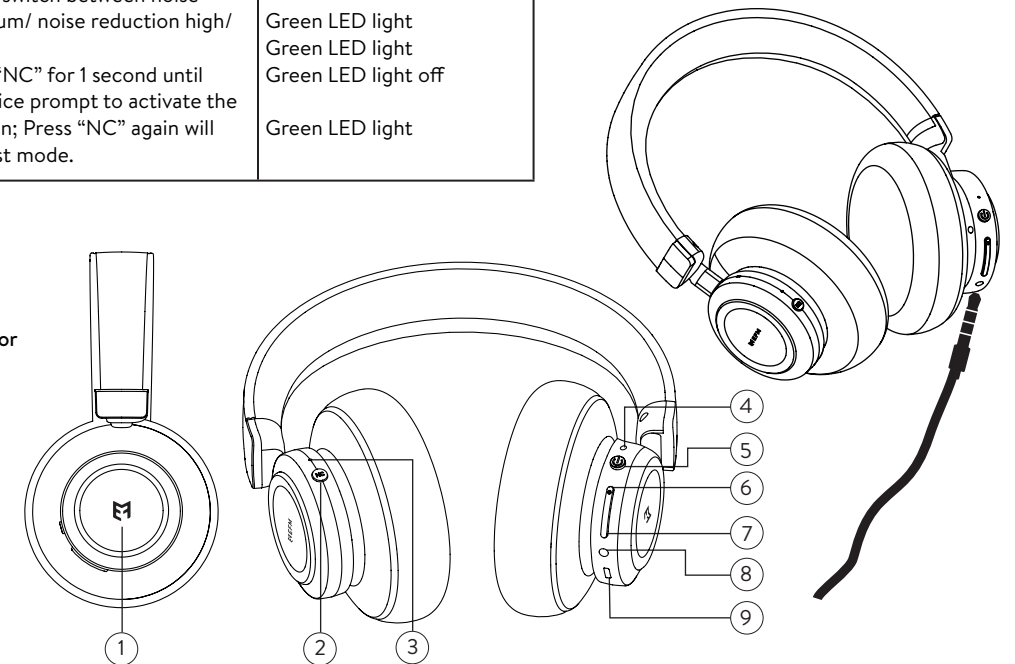

## Charging

Plug the charging cable into the Micro-USB connector on the right ear cup.

## Reset

If the headphones turn off and can't be turned on, simultaneously press and hold "NC" and plug the Micro-USB charging cable to charge the headphone until you see the red LED light indicator.

## Caution

1. Avoid playing the unit at the high volume for extended periods of time to prevent your hearing from being impaired.
2. Keep the headphones away from chemicals and magnetic materials. Always keep the product dry and do not expose it to extreme temperatures to avoid corrosion or deformation.
3. The built-in battery needs to be charged when sound becomes low.

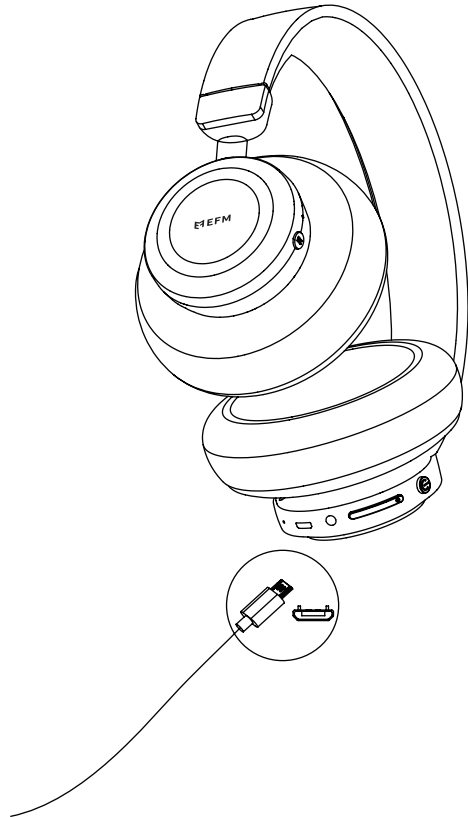

## Warranty

Our goods come with guarantees that cannot be excluded under the Australian Consumer Law. You are entitled to a replacement or refund for a major failure and compensation for any other reasonably foreseeable loss or damage. You are also entitled to have the goods repaired or replaced if the goods fail to be of acceptable quality and the failure does not amount to a major failure.

EFM<sup>®</sup> warrants that its products are free from defects in materials or workmanship for up to 2 years from the date of purchase. EFM<sup>®</sup> will repair or replace any product which is defective in materials or workmanship at no charge to the customer (for parts or labour). The customer is responsible for any transportation costs.

This warranty only applies to EFM<sup>®</sup> products purchased by you, and does not extend to or cover damage caused by the incorrect use or installation of the EFM<sup>®</sup> product, through your modification of the EFM<sup>®</sup> product, cosmetic damage, general wear and tear, or damage caused by accident. This warranty does not apply to any consequential loss or damages which may be incurred through your use of the EFM<sup>®</sup> product, including but not limited to damage of any nature caused to any products used in conjunction with the EFM<sup>®</sup> product.

To claim under the warranty, you need to return the faulty EFM<sup>®</sup> product to the place of purchase (at your expense) with a valid proof of purchase. If you are not able to return the product to the place of purchase, you can contact:

EFM<sup>®</sup> Customer Service Department  
PO BOX 684, Belmont WA 6104  
P: 1300 069 336 (1300 0 MYEFM)  
E: info@myefm.com

Important: For the avoidance of any doubt, this 2 Year Warranty applies to your purchased EFM<sup>®</sup> product only, and not to any device to which the EFM<sup>®</sup> product is affixed or used in conjunction with. Whilst we stand by our products, EFM<sup>®</sup> will not be liable for any damages of any nature caused to any such device from incorrect use of the product.

**MEFM**

[myefm.com](http://myefm.com)